

5KP SERIES TRANSIENT VOLTAGE SUPPRESSOR

Features:

- Glass Passivated Die Construction
- 5000W Peak Pulse Power Dissipation
- 5.0V- 110V Standoff Voltage
- Uni- and Bi-Directional Versions Available
- Excellent Clamping Capability
- Fast Response Time
- Plastic Case Material has UL Flammability Classification Rating 94V-0
- This is a Pb – Free Device
- All SMC Parts are Traceable to the Wafer Lot
- Additional testing can be offered upon request

Mechanical Data:

- Case: JEDEC P-600 Molded Plastic
- Terminals: Axial Leads, Solderable per MIL-STD 750, Method 2026
- Polarity: Cathode Band or Cathode Notch
- Weight: 2.10 grams(approx.)

Mechanical Dimensions: In Inches (mm)

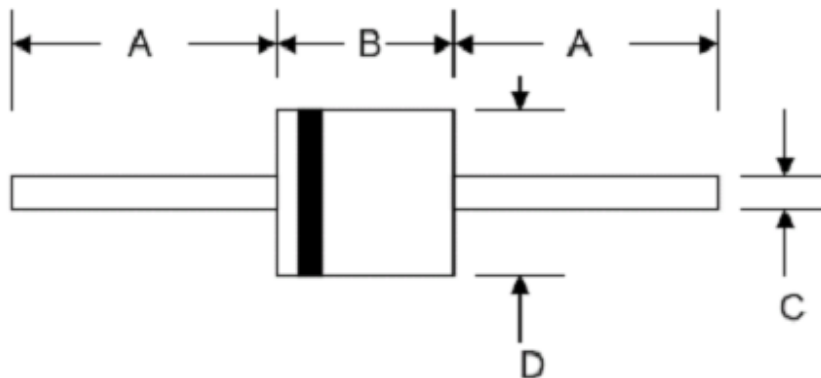

P-600				
Dim	Min	Max	Min	Max
A	25.4	—	1.000	—
B	8.60	9.10	0.339	0.358
C	1.20	1.30	0.047	0.051
D	8.60	9.10	0.339	0.358
	In mm		In inch	

P-600

- China - Germany - Korea - Singapore - United States •
- <http://www.smc-diodes.com> - sales@smc-diodes.com •

Technical Data
Data Sheet N0213, Rev. -

Green Products

Marking Diagram

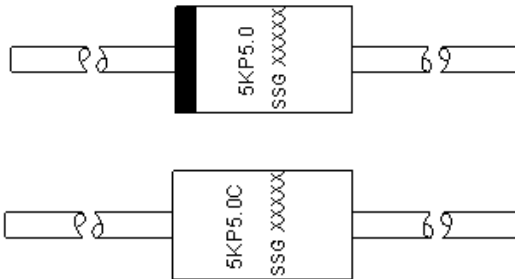

Where XXXXX is YYWWL

5KP5.0/C = Part Name
SSG = SSG
YY = Year
WW = Week
L = Lot Number

Cautions: Molding resin
Epoxy resin UL: 94V-0

Ordering Information

Device	Package	Shipping
5KP SERIES	P-600 (Pb-Free)	800pcs / reel

For information on tape and reel specifications, including part orientation and tape sizes, please refer to our Tape and Reel Packaging Specification.

Maximum Ratings and Electrical Characteristics @ $T_A=25^\circ\text{C}$ unless otherwise specified

Parameter	Symbol	Value	Unit
Peak Pulse Power Dissipation at $T_A=25^\circ\text{C}$ (Fig.1)(Note 1, 2, 5)	P_{PPM}	5000	W
Peak Forward Surge Current, 8.3ms Single Half Sine Wave (Fig.6),(Note 3)	I_{FSM}	400	A
Peak Pulse Current on 10x1000 μs Waveform(Fig.3)(Note 1)	I_{PPM}	See Table 1	A
Steady State Power Dissipation (Note 2, 4)	$P_{M(AV)}$	8.0	W
Operating Junction and Storage Temperature Range	T_J, T_{STG}	-55 to 175	$^\circ\text{C}$

- Notes:**
1. Non-repetitive current pulse, per Fig. 3 and derated above $T_A = 25^\circ\text{C}$ per Fig. 2.
 2. Mounted on 20mm² copper pads.
 3. 8.3ms single half sine wave, duty cycle=4 pulses per minute maximum.
 4. Lead temperature at $75^\circ\text{C}=T_L$
 5. Peak pulse power waveform is 10x1000 μs

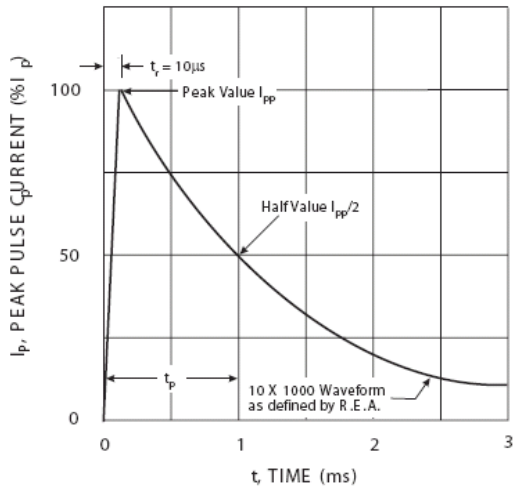

Fig. 1 Pulse Waveform

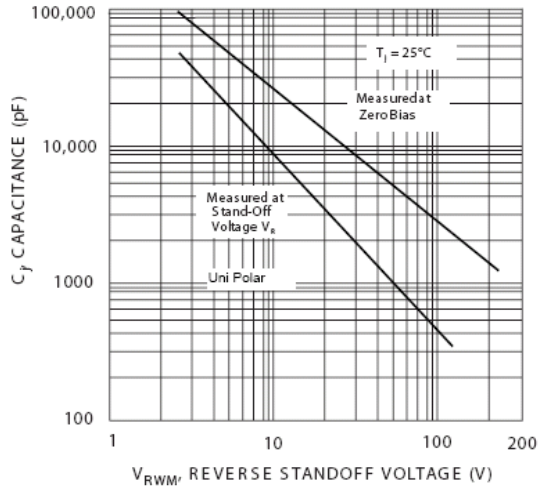

Fig. 2 Typical Junction Capacitance

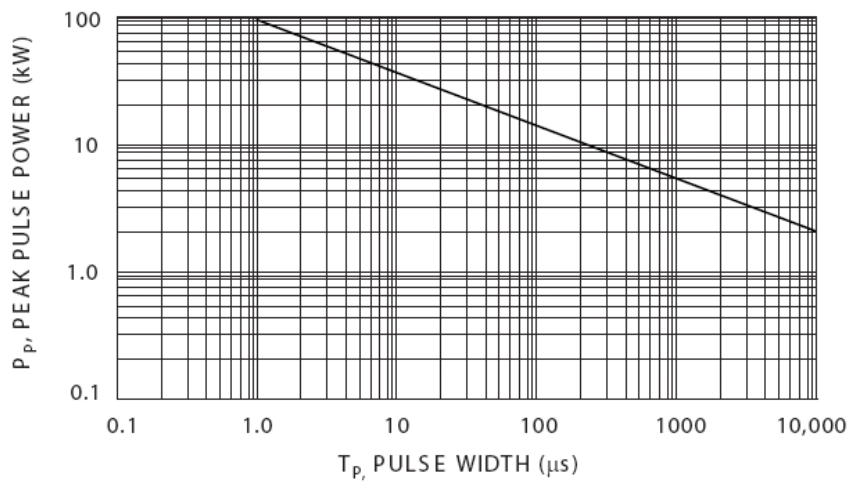

Fig. 3 Pulse Derating Curve

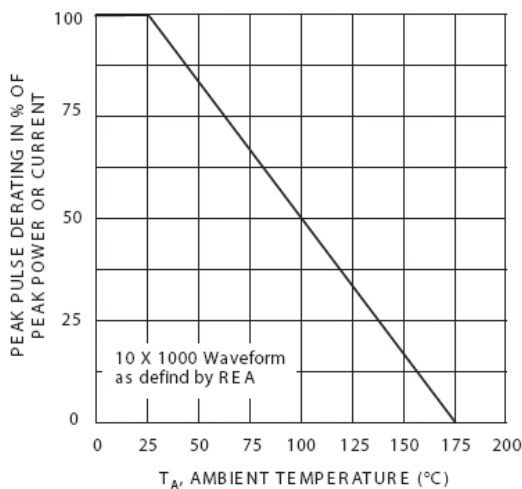

Fig. 4 Pulse Derating Curve

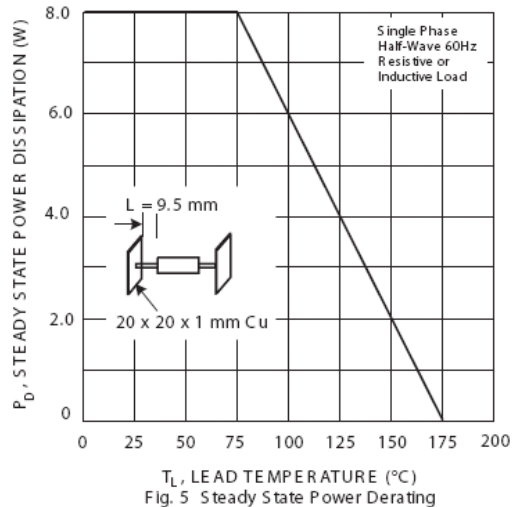

Fig. 5 Steady State Power Derating



Technical Data
Data Sheet N0213, Rev. -

Green Products

UNI-DIRECTIONAL 5000 WATT AXIAL LEAD TVS

UNI-DIRECTIONAL PART NUMBER	REVERSE STAND-OFF VOLTAGE VRWM (V)	BREAKDOWN VOLTAGE VBR (V) MIN. @IT	BREAKDOWN VOLTAGE VBR (V) MAX. @IT	TEST CURRENT IT (mA)	MAXIMUM CLAMPING VOLTAGE @Ipp Vc (V)	PEAK PULSE CURRENT Ipp (A)	REVERSE LEAKAGE @VRWM IR (uA)
5KP5.0	5.00	6.40	7.82	50	9.6	520	2000
5KP5.0A	5.00	6.40	7.00	50	9.2	543	2000
5KP6.0	6.00	6.67	8.15	50	11.4	439	5000
5KP6.0A	6.00	6.67	7.37	50	10.3	485	5000
5KP6.5	6.50	7.22	8.82	50	12.3	407	2000
5KP6.5A	6.50	7.22	7.98	50	11.2	447	2000
5KP7.0	7.00	7.78	9.51	50	13.3	378	1000
5KP7.0A	7.00	7.78	8.60	50	12.0	417	1000
5KP7.5	7.50	8.33	10.02	5	14.3	350	250
5KP7.5A	7.50	8.33	9.21	5	12.9	388	250
5KP8.0	8.00	8.99	10.90	5	15.0	333	150
5KP8.0A	8.00	8.99	9.83	5	13.6	367	150
5KP8.5	8.50	9.44	11.50	5	15.9	314	50
5KP8.5A	8.50	9.44	10.40	5	14.4	347	50
5KP9.0	9.00	10.00	12.20	5	16.9	295	20
5KP9.0A	9.00	10.00	11.20	5	15.4	325	20
5KP10	10.00	11.10	13.60	5	18.8	266	10
5KP10A	10.00	11.10	12.30	5	17.0	294	10
5KP11	11.00	12.20	14.90	5	20.1	249	10
5KP11A	11.00	12.20	13.50	5	18.2	274	10
5KP12	12.00	13.30	16.30	5	22.0	227	10
5KP12A	12.00	13.30	14.70	5	19.9	251	10
5KP13	13.00	14.40	17.60	5	23.8	210	10
5KP13A	13.00	14.40	15.90	5	21.5	232	10
5KP14	14.00	15.60	19.10	5	25.8	194	10
5KP14A	14.00	15.60	17.20	5	23.2	215	10
5KP15	15.00	16.70	20.40	5	26.9	188	10
5KP15A	15.00	16.70	18.50	5	24.4	206	10
5KP16	16.00	17.80	21.80	5	28.8	176	10
5KP16A	16.00	17.80	19.70	5	26.0	192	10
5KP17	17.00	18.90	23.10	5	30.5	164	10
5KP17A	17.00	18.90	20.90	5	27.6	181	10
5KP18	18.00	20.00	24.40	5	32.2	155	10
5KP18A	18.00	20.00	22.10	5	29.2	172	10
5KP20	20.00	22.20	27.10	5	35.8	139	10
5KP20A	20.00	22.20	24.50	5	32.4	154	10
5KP22	22.00	24.40	29.80	5	39.4	127	10
5KP22A	22.00	24.40	26.90	5	35.5	141	10
5KP24	24.00	26.70	32.60	5	43.0	116	10
5KP24A	24.00	26.70	29.50	5	38.9	128	10
5KP26	26.00	28.90	35.30	5	46.6	107	10
5KP26A	26.00	28.90	31.90	5	42.1	119	10
5KP28	28.00	31.10	38.00	5	50.0	99	10
5KP28A	28.00	31.10	34.40	5	45.4	110	10
5KP30	30.00	33.30	40.70	5	53.5	93	10
5KP30A	30.00	33.30	36.90	5	48.4	103	10
5KP33	33.00	36.70	44.90	5	59.0	85	10
5KP33A	33.00	36.70	40.60	5	53.3	94	10
5KP36	36.00	40.00	48.90	5	64.3	78	10
5KP36A	36.00	40.00	44.20	5	58.1	85	10
5KP40	40.00	44.40	54.30	5	71.4	70	10
5KP40A	40.00	44.40	49.10	5	64.5	78	10
5KP43	43.00	47.80	58.40	5	76.6	65	10
5KP43A	43.00	47.80	52.80	5	69.4	72	10
5KP45	45.00	50.00	61.10	5	80.3	62	10
5KP45A	45.00	50.00	55.30	5	72.7	69	10
5KP48	48.00	53.30	65.10	5	85.5	58	10
5KP48A	48.00	53.30	58.90	5	77.4	65	10
5KP51	51.00	56.70	69.30	5	91.1	55	10
5KP51A	51.00	56.70	62.70	5	82.4	61	10
5KP54	54.00	60.00	73.30	5	96.3	52	10
5KP54A	54.00	60.00	66.30	5	87.1	57	10
5KP58	58.00	64.40	78.70	5	103.0	49	10
5KP58A	58.00	64.40	71.20	5	93.6	53	10
5KP60	60.00	66.70	81.50	5	107.0	47	10
5KP60A	60.00	66.70	73.70	5	96.8	52	10
5KP64	64.00	71.10	86.90	5	114.0	44	10
5KP64A	64.00	71.10	78.60	5	103.0	49	10
5KP70	70.00	77.80	95.10	5	125.0	40	10
5KP70A	70.00	77.80	86.00	5	113.0	44	10
5KP75	75.00	83.30	102.00	5	134.0	37	10
5KP75A	75.00	83.30	92.10	5	121.0	41	10
5KP78	78.00	86.70	106.00	5	139.0	36	10
5KP78A	78.00	86.70	95.80	5	126.0	40	10
5KP85	85.00	94.40	115.00	5	151.0	33	10
5KP85A	85.00	94.40	104.00	5	137.0	36	10
5KP90	90.00	100.00	122.00	5	160.0	31	10
5KP90A	90.00	100.00	111.00	5	146.0	34	10
5KP100	100.00	111.00	136.00	5	179.0	28	10
5KP100A	100.00	111.00	123.00	5	162.0	31	10
5KP110	110.00	122.00	149.00	5	196.0	26	10
5KP110A	110.00	122.00	135.00	5	177.0	28	10

"C" Suffix Designates Bi-directional Devices
"A" Suffix Designates 5% Tolerance Devices
No Suffix Designates 10% Tolerance Devices

- China - Germany - Korea - Singapore - United States •
- <http://www.smc-diodes.com> - sales@smc-diodes.com •



Technical Data
Data Sheet N0213, Rev. -

Green Products

BI-DIRECTIONAL 5000 WATT AXIAL LEAD TVS

BI-DIRECTIONAL PART NUMBER	REVERSE STAND-OFF VOLTAGE VRWM (V)	BREAKDOWN VOLTAGE VBR (V) MIN. @IT	BREAKDOWN VOLTAGE VBR (V) MAX. @IT	TEST CURRENT IT (mA)	MAXIMUM CLAMPING VOLTAGE @Ipp Vc (V)	PEAK PULSE CURRENT Ipp (A)	REVERSE LEAKAGE @VRWM IR (µA)
5KP5.0C	5.00	6.40	7.82	50	9.6	520	4000
5KP5.0CA	5.00	6.40	7.00	50	9.2	543	4000
5KP6.0C	6.00	6.67	8.15	50	11.4	439	10000
5KP6.0CA	6.00	6.67	7.37	50	10.3	485	10000
5KP6.5C	6.50	7.22	8.82	50	12.3	407	4000
5KP6.5CA	6.50	7.22	7.98	50	11.2	447	4000
5KP7.0C	7.00	7.78	9.51	50	13.3	378	2000
5KP7.0CA	7.00	7.78	8.60	50	12.0	417	2000
5KP7.5C	7.50	8.33	10.02	5	14.3	350	500
5KP7.5CA	7.50	8.33	9.21	5	12.9	388	500
5KP8.0C	8.00	8.99	10.90	5	15.0	333	300
5KP8.0CA	8.00	8.99	9.83	5	13.6	367	300
5KP8.5C	8.50	9.44	11.50	5	15.9	314	100
5KP8.5CA	8.50	9.44	10.40	5	14.4	347	100
5KP9.0C	9.00	10.00	12.20	5	16.9	295	40
5KP9.0CA	9.00	10.00	11.20	5	15.4	325	40
5KP10C	10.00	11.10	13.60	5	18.8	266	10
5KP10CA	10.00	11.10	12.30	5	17.0	294	10
5KP11C	11.00	12.20	14.90	5	20.1	249	10
5KP11CA	11.00	12.20	13.50	5	18.2	274	10
5KP12C	12.00	13.30	16.30	5	22.0	227	10
5KP12CA	12.00	13.30	14.70	5	19.9	251	10
5KP13C	13.00	14.40	17.60	5	23.8	210	10
5KP13CA	13.00	14.40	15.90	5	21.5	232	10
5KP14C	14.00	15.60	19.10	5	25.8	194	10
5KP14CA	14.00	15.60	17.20	5	23.2	215	10
5KP15C	15.00	16.70	20.40	5	26.9	188	10
5KP15CA	15.00	16.70	18.50	5	24.4	206	10
5KP16C	16.00	17.80	21.80	5	28.8	176	10
5KP16CA	16.00	17.80	19.70	5	26.0	192	10
5KP17C	17.00	18.90	23.10	5	30.5	164	10
5KP17CA	17.00	18.90	20.90	5	27.6	181	10
5KP18C	18.00	20.00	24.40	5	32.2	155	10
5KP18CA	18.00	20.00	22.10	5	29.2	172	10
5KP20C	20.00	22.20	27.10	5	35.8	139	10
5KP20CA	20.00	22.20	24.50	5	32.4	154	10
5KP22C	22.00	24.40	29.80	5	39.4	127	10
5KP22CA	22.00	24.40	26.90	5	35.5	141	10
5KP24C	24.00	26.70	32.60	5	43.0	116	10
5KP24CA	24.00	26.70	29.50	5	38.9	128	10
5KP26C	26.00	28.90	35.30	5	46.6	107	10
5KP26CA	26.00	28.90	31.90	5	42.1	119	10
5KP28C	28.00	31.10	38.00	5	50.0	99	10
5KP28CA	28.00	31.10	34.40	5	45.4	110	10
5KP30C	30.00	33.30	40.70	5	53.5	93	10
5KP30CA	30.00	33.30	36.90	5	48.4	103	10
5KP33C	33.00	36.70	44.90	5	59.0	85	10
5KP33CA	33.00	36.70	40.60	5	53.3	94	10
5KP36C	36.00	40.00	48.90	5	64.3	78	10
5KP36CA	36.00	40.00	44.20	5	58.1	85	10
5KP40C	40.00	44.40	54.30	5	71.4	70	10
5KP40CA	40.00	44.40	49.10	5	64.5	78	10
5KP43C	43.00	47.80	58.40	5	76.6	65	10
5KP43CA	43.00	47.80	52.80	5	69.4	72	10
5KP45C	45.00	50.00	61.10	5	80.3	62	10
5KP45CA	45.00	50.00	55.30	5	72.7	69	10
5KP48C	48.00	53.30	65.10	5	85.5	58	10
5KP48CA	48.00	53.30	58.90	5	77.4	65	10
5KP51C	51.00	56.70	69.30	5	91.1	55	10
5KP51CA	51.00	56.70	62.70	5	82.4	61	10
5KP54C	54.00	60.00	73.30	5	96.3	52	10
5KP54CA	54.00	60.00	66.30	5	87.1	57	10
5KP58C	58.00	64.40	78.70	5	103.0	49	10
5KP58CA	58.00	64.40	71.20	5	93.6	53	10
5KP60C	60.00	66.70	81.50	5	107.0	47	10
5KP60CA	60.00	66.70	73.70	5	96.8	52	10
5KP64C	64.00	71.10	86.90	5	114.0	44	10
5KP64CA	64.00	71.10	78.60	5	103.0	49	10
5KP70C	70.00	77.80	95.10	5	125.0	40	10
5KP70CA	70.00	77.80	86.00	5	113.0	44	10
5KP75C	75.00	83.30	102.00	5	134.0	37	10
5KP75CA	75.00	83.30	92.10	5	121.0	41	10
5KP78C	78.00	86.70	106.00	5	139.0	36	10
5KP78CA	78.00	86.70	95.80	5	126.0	40	10
5KP85C	85.00	94.40	115.00	5	151.0	33	10
5KP85CA	85.00	94.40	104.00	5	137.0	36	10
5KP90C	90.00	100.00	122.00	5	160.0	31	10
5KP90CA	90.00	100.00	111.00	5	146.0	34	10
5KP100C	100.00	111.00	136.00	5	179.0	28	10
5KP100CA	100.00	111.00	123.00	5	162.0	31	10
5KP110C	110.00	122.00	149.00	5	196.0	26	10
5KP110CA	110.00	122.00	135.00	5	177.0	28	10

"C" Suffix Designates Bi-directional Devices
"A" Suffix Designates 5% Tolerance Devices
No Suffix Designates 10% Tolerance Devices



DISCLAIMER:

- 1- The information given herein, including the specifications and dimensions, is subject to change without prior notice to improve product characteristics. Before ordering, purchasers are advised to contact the SMC - Sangdest Microelectronics (Nanjing) Co., Ltd sales department for the latest version of the datasheet(s).
- 2- In cases where extremely high reliability is required (such as use in nuclear power control, aerospace and aviation, traffic equipment, medical equipment, and safety equipment), safety should be ensured by using semiconductor devices that feature assured safety or by means of users' fail-safe precautions or other arrangement.
- 3- In no event shall SMC - Sangdest Microelectronics (Nanjing) Co., Ltd be liable for any damages that may result from an accident or any other cause during operation of the user's units according to the datasheet(s). SMC - Sangdest Microelectronics (Nanjing) Co., Ltd assumes no responsibility for any intellectual property claims or any other problems that may result from applications of information, products or circuits described in the datasheets.
- 4- In no event shall SMC - Sangdest Microelectronics (Nanjing) Co., Ltd be liable for any failure in a semiconductor device or any secondary damage resulting from use at a value exceeding the absolute maximum rating.
- 5- No license is granted by the datasheet(s) under any patents or other rights of any third party or SMC - Sangdest Microelectronics (Nanjing) Co., Ltd.
- 6- The datasheet(s) may not be reproduced or duplicated, in any form, in whole or part, without the expressed written permission of SMC - Sangdest Microelectronics (Nanjing) Co., Ltd.
- 7- The products (technologies) described in the datasheet(s) are not to be provided to any party whose purpose in their application will hinder maintenance of international peace and safety nor are they to be applied to that purpose by their direct purchasers or any third party. When exporting these products (technologies), the necessary procedures are to be taken in accordance with related laws and regulations..